

High Performance Crystal Radios

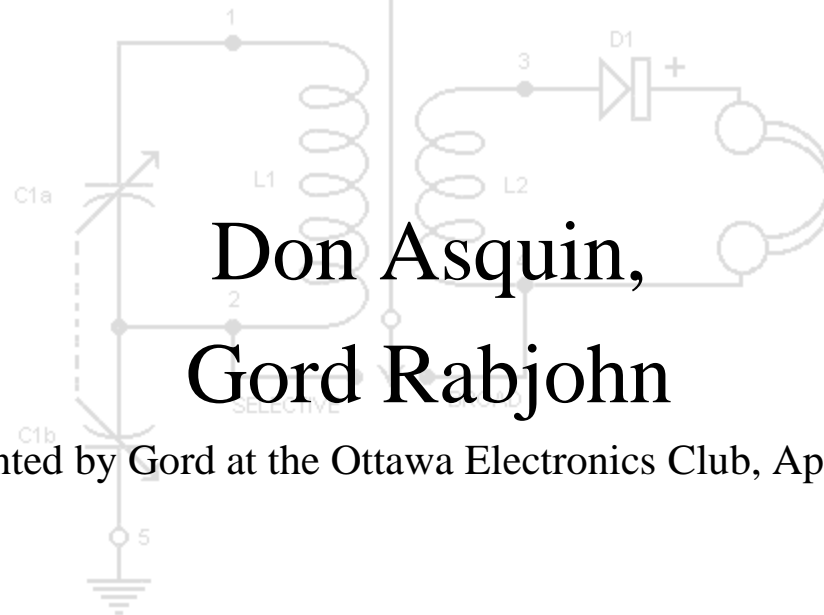

Don Asquin,
Gord Rabjohn

(Presented by Gord at the Ottawa Electronics Club, April 2012)

Childhood History



www.crystalradio.net

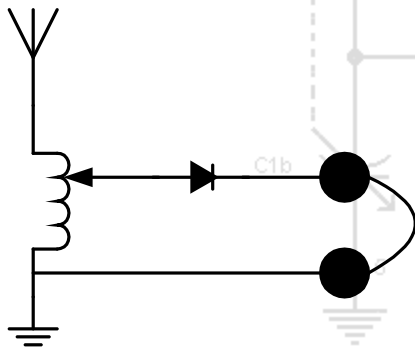

- Like many kids, I had frustrating childhood experiences with crystal radios!
- Simple crystal sets couldn't separate multiple AM radio stations.
- Only local stations were received, and everything was received all at once.

Rediscovering History

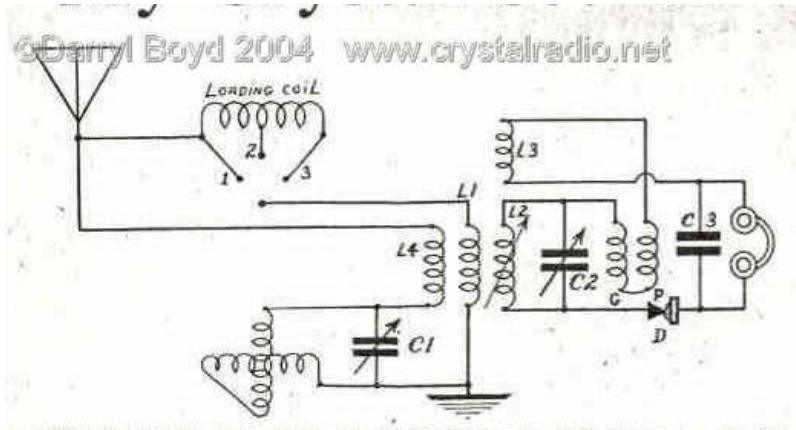

www.crystalradio.net

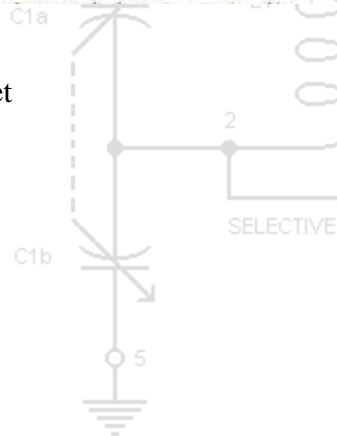

- Recently, my friend Don Asquin and I decided to build high performance crystal sets.
- Much of this exploration is rediscovering the knowledge of the 1910s and early 1920s.
- Even then there were claims of DX performance with crystal sets.

How does a basic crystal set work?

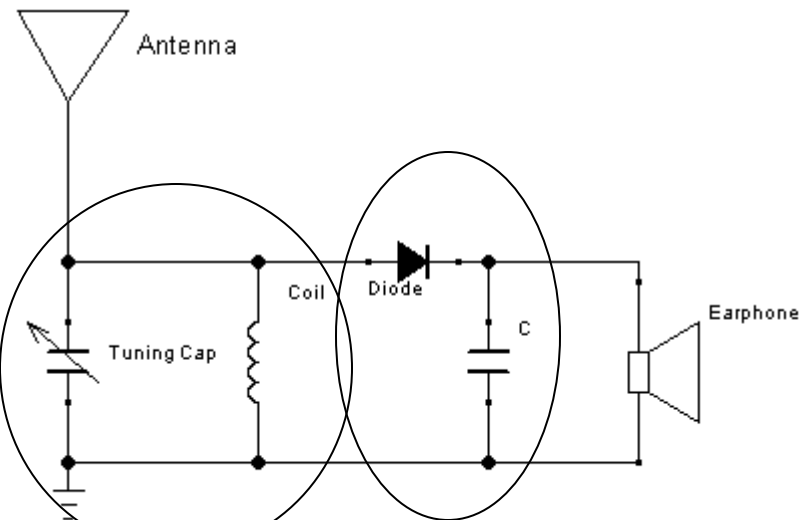

A filter

At low frequency, the inductor shorts the signal out. At high frequency the capacitor shorts the signal out. In-between, there is a magic point called “resonance”

- Antenna couples to the (usually) electric field in a radio wave.
- L-C selects the frequency.
- Diode rectifies it.
- Earphone makes it audible

AM modulated signal

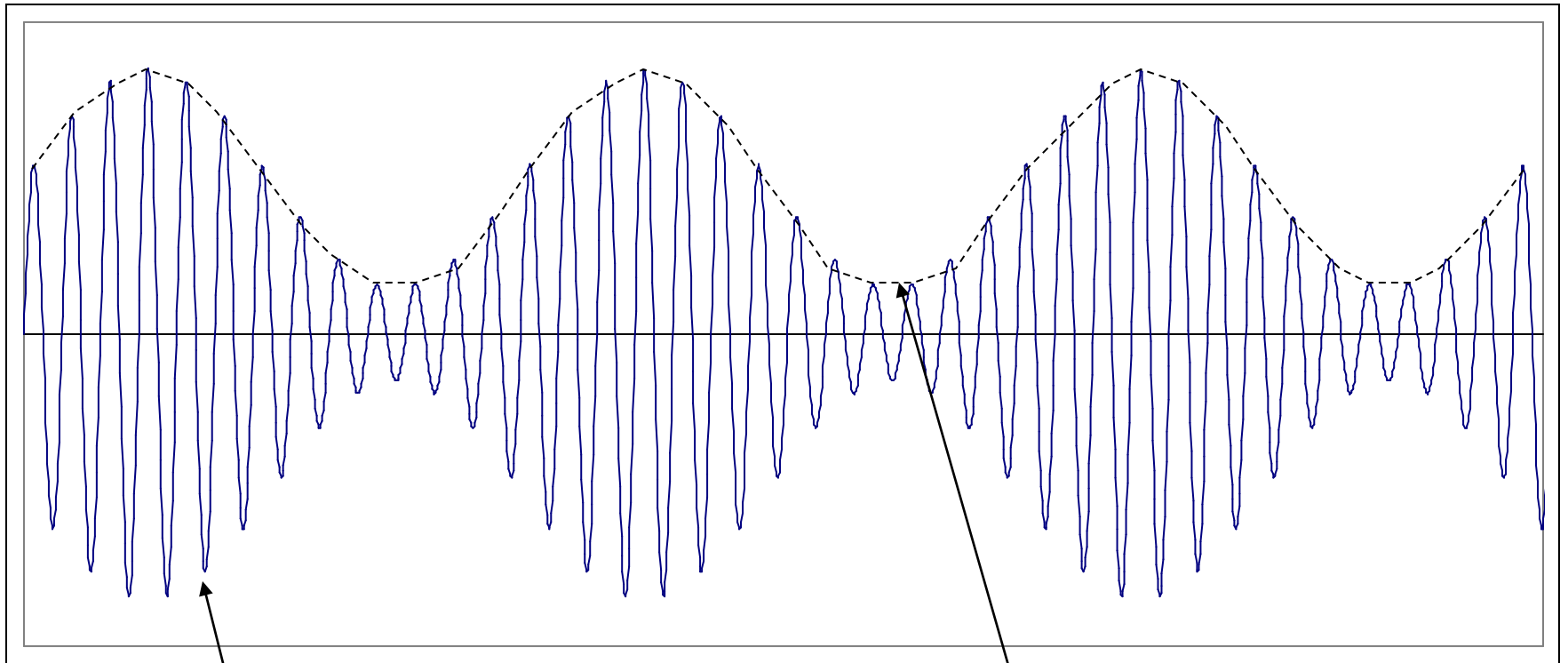

RF Carrier frequency (say 1310kHz):
the filter selects only this frequency.

Rectified audio output,
smoothed by the capacitor

The Four Key Elements



www.crystalradio.net

- Antenna
 - Antenna
 - Ground
- Tuner
 - Loose coupler
 - High Q coils
 - RF impedance matching
- Detector
- Audio Transducer
 - Audio Impedance matching



Y Antenna Y

- A long exterior antenna is crucial.
- Why? It's not just about area... “watts per acre”. It's also about giving the antenna a better “radiation impedance”.
 - The energy from an antenna, can be modeled as a voltage source in series with a source resistance (or a current source in parallel with a source conductance), and the antenna capacitance (or inductance).
 - Radiation resistance is the resistance of this apparent source of energy in an antenna.
 - The tuned circuit matches this impedance to the load (detector) for optimum energy transfer.
 - A small antenna will tend to look like a “difficult to match” impedance....

My Antenna:

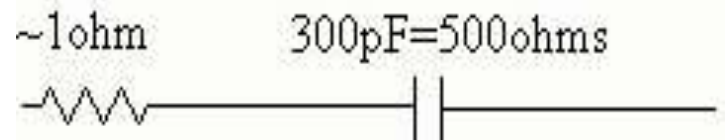

⏚ Ground ⏚

- The ground provides the completion of the current path for the radio signals.
- You can always attach a wire to a cold water pipe, but the best ground remains a copper plated rod pounded into the ground.
- Home Depot sells these rods for grounding electrical systems.
- If installed near a water tap, the ground can be kept moist and conductive.

Tuner

-Antenna Tuner

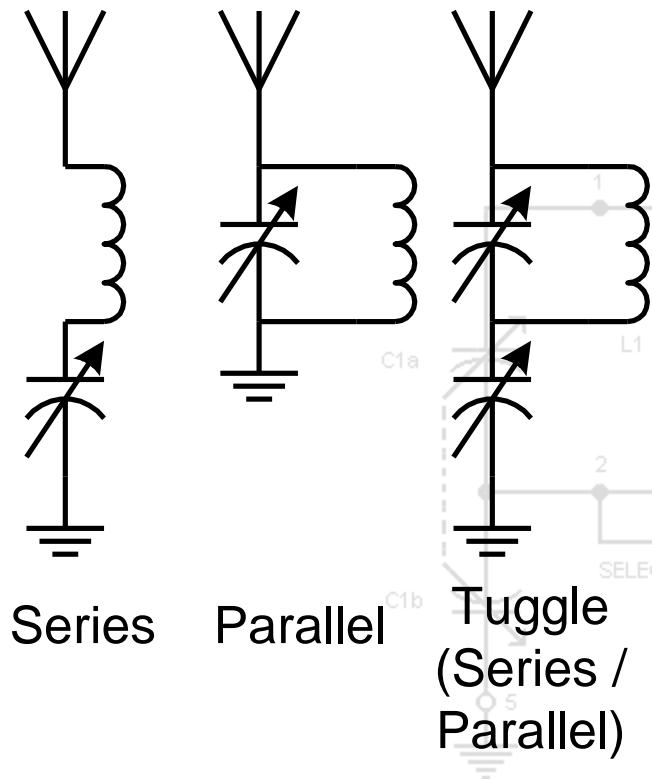

- To extract the most power, you need to match the resistance of the load (detector and earphone) to the impedance of the source (antenna)
- The function of the tuner is to match the radiation resistance of the antenna to the impedance of the detector, and to provide selectivity.

Tuner

-Loose Coupler



www.crystalradio.net

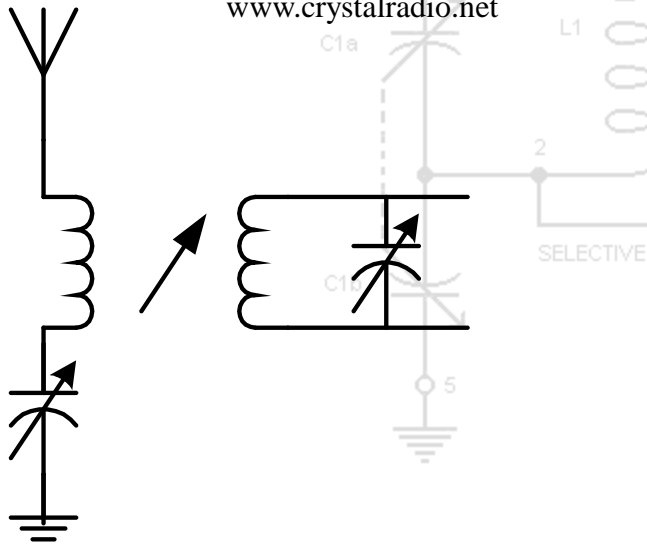

- The loose coupler is simply two coils (each generally resonated with a capacitor) lightly coupled to each other.
- One coil is connected to the antenna, the other is connected to the detector.
- Even cheap capacitors tend to be quite good, but high Q inductor fabrication is an “art”.

Loose Coupler

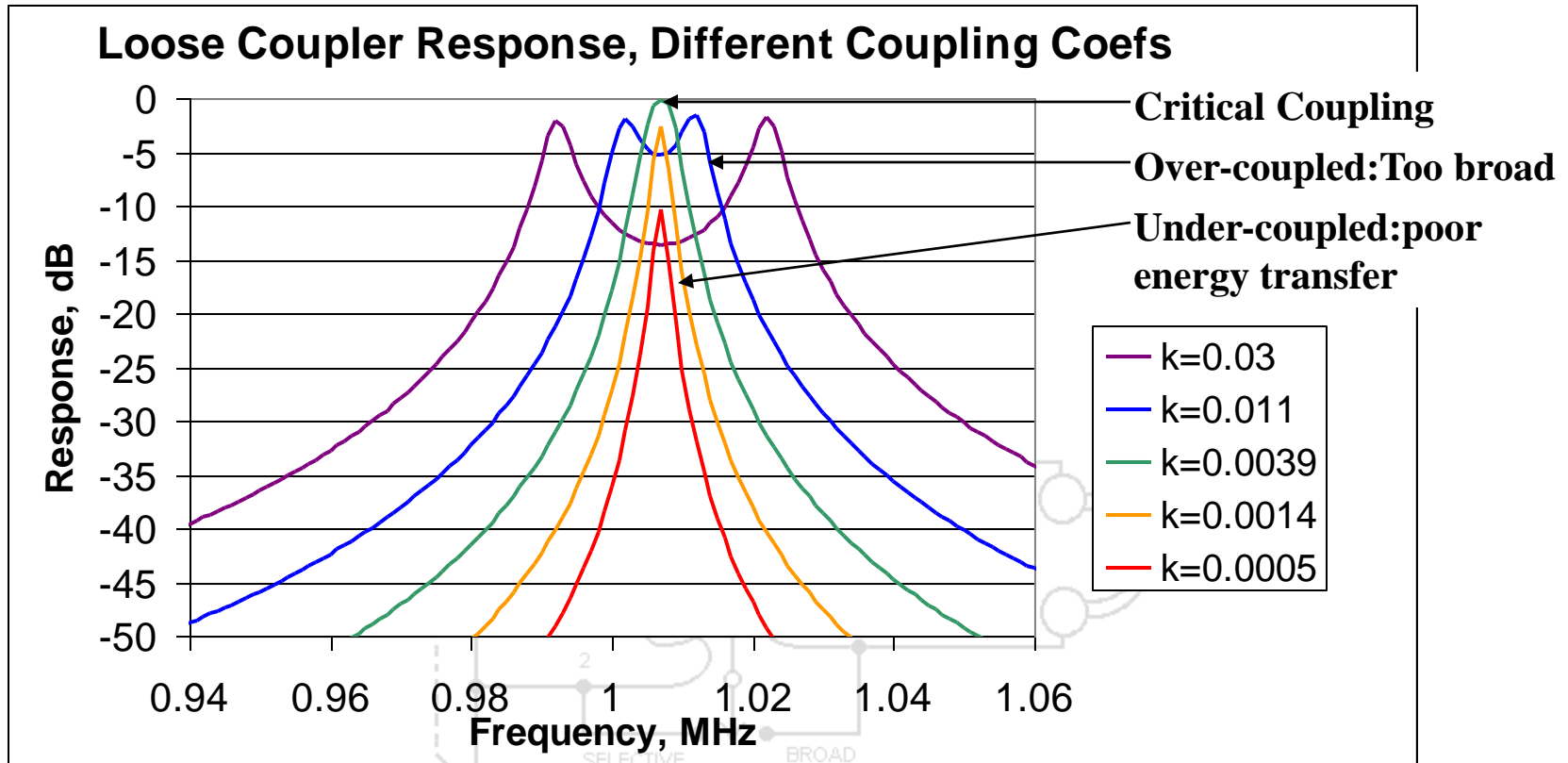

Simulation of 1000pF, 1.0 ohm antenna, 100uH primary coil and ~330pF cap, coupled to a 100uH secondary coil, 250pF cap, 100k load.

- There is an optimum amount of coupling between the coils. (=1/Q). This is VERY LIGHT coupling. Under 1% of the magnetic field is coupled.

Coil “Q” = Quality

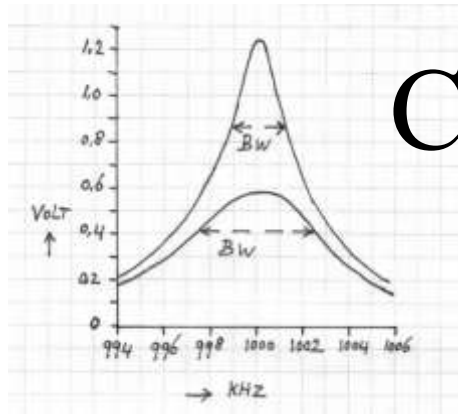

www.crystal-radio.eu

$$Q = \frac{\text{Frequency}}{\text{Bandwidth}}$$

Station Frequency (kHz)	Minimum Q
540	54
1000	100
1600	160
Assume Q=160	
Station Frequency (kHz)	Audio Bandwidth (kHz)
540	1.7
1000	3.1
1600	5.0

- For a tuned circuit “Q” is the ratio of the center frequency to the bandwidth.
- For a coil, it is the ratio of energy lost to energy stored.
- Q is very difficult to accurately measure.
- You can never have too much Q!
- The inductor is usually the part with the poorest “Q”, so a lot of creative energy is invested into optimum devices.

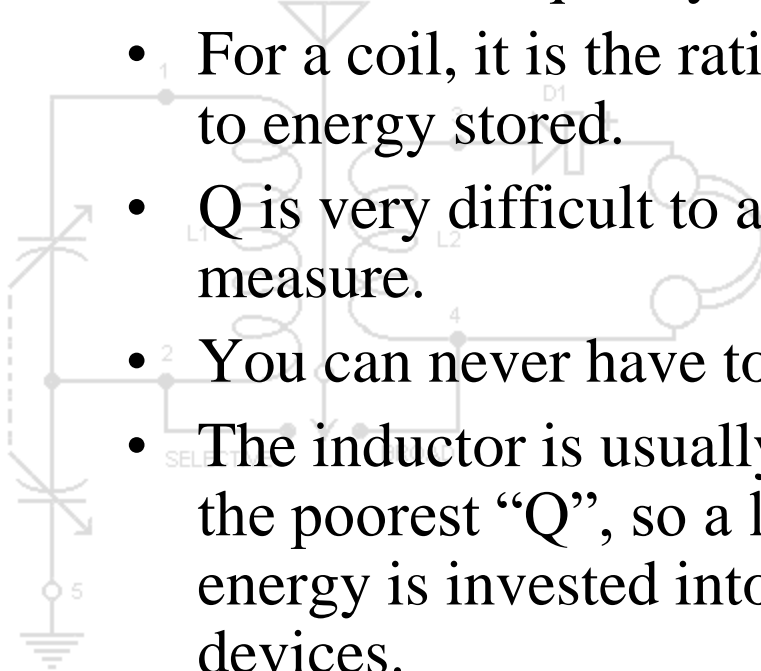

Coil Types



www.wynterarchtops.com

SELECTIVE

- The highest “Q” coils seem to be air core.
- Many different variations
 - Spider web,
 - Basket weave
 - Honey Comb
- All attempt to reduce capacitance and current crowding to increase Q

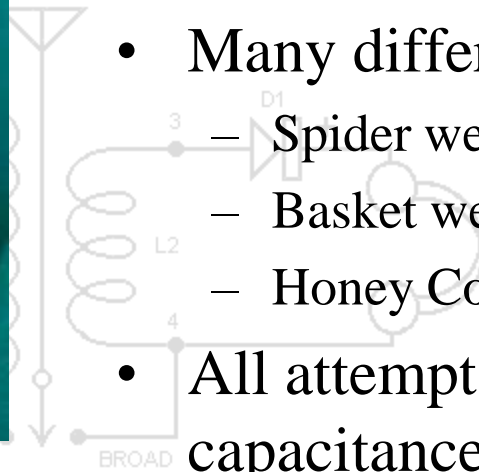

Coil Winding Jig

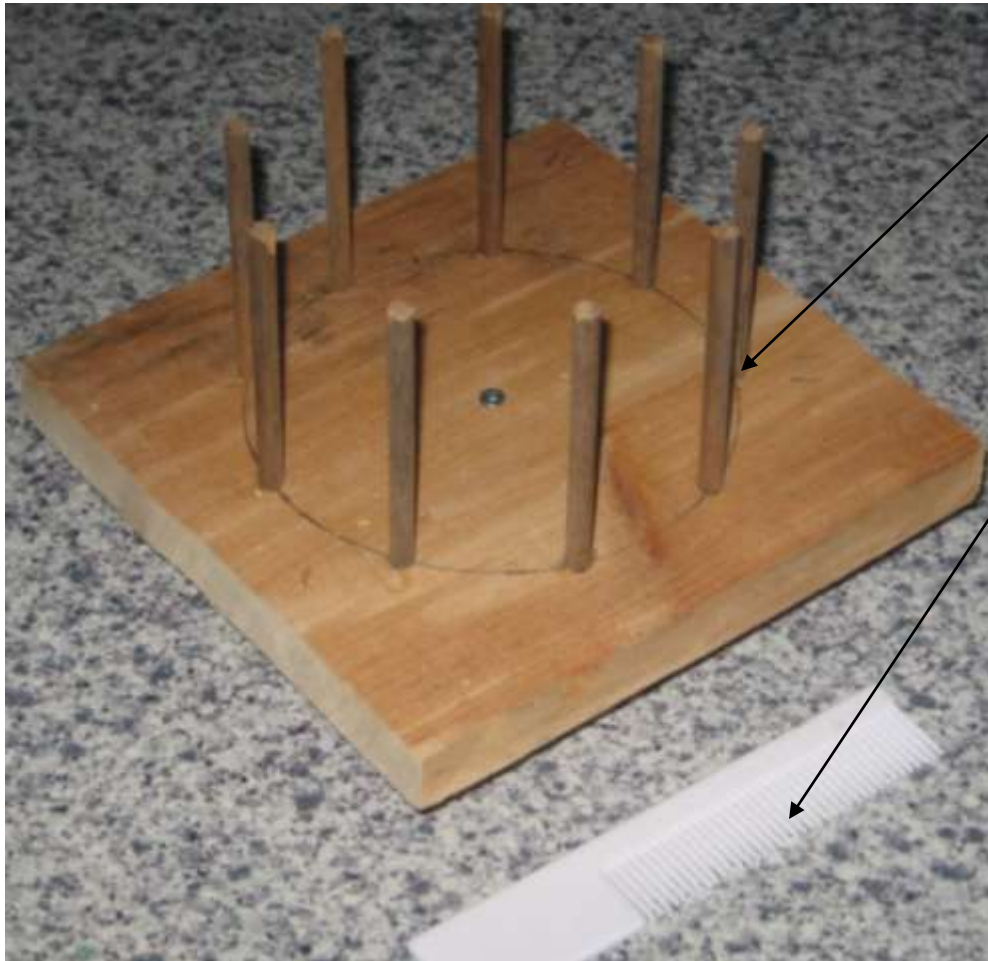

Drinking straws fit over 1/4" dowels.

Comb helps space wires



Litz Wire



www.newenglandwire.com

- Best wire for high “Q” coils is Litz wire.
- Litz is derived from the German word “Litzendraht” meaning woven wire.
- Consists of many strands of parallel connected, individually insulated wire woven together in a regular pattern.
- Each wire alternates between the middle and the outside of the bundle.
- Each wire forced to carry about the same current, minimizing skin effect (the tendency for current to flow along the outside surface of a wire), and loss.
- The holy grail of litz wire is made up of 420 to 660 individual strands of 46 AWG wire all twisted together to make a 16-18 AWG wire.
- One comparison: A basket wound coil with solid copper wire (~200uH) has a Q of 230 at 1MHz. With Litz wire, it has a Q of over 500!



www.crystalradio.net



Detector



- In my experience, nothing beats a good 1N34A germanium diode. (Still widely available)
- Germanium is good because its barrier height (turn-on voltage) is lower than silicon, and a germanium diode is truly a point-contact diode (Schottky, not P-N diode), so has low charge storage (and therefore fast switching times).
- Specified with very low capacitance, less than 1.0pF.
- Main complaint about 1N34A diodes is that they tend to have high and highly variable leakage.
- Best solution is to try several, doing A B comparisons and select the best germanium diode in your drawer .

Detector Impedance

- Detectors are most efficient when driven with *high voltages*.
 - Detectors are “square law” devices (at low power), output voltage is proportional to square of input voltage.
- Since we have a fixed amount of input *power*, we need to increase voltage and decrease current applied to the detector (Power=Voltage x Current); in other words increase the detector *impedance*.
- At detector input: use a loose coupler.
- At detector output: use a 100kohm microphone transformer to match into the headphones.

Germanium Diodes

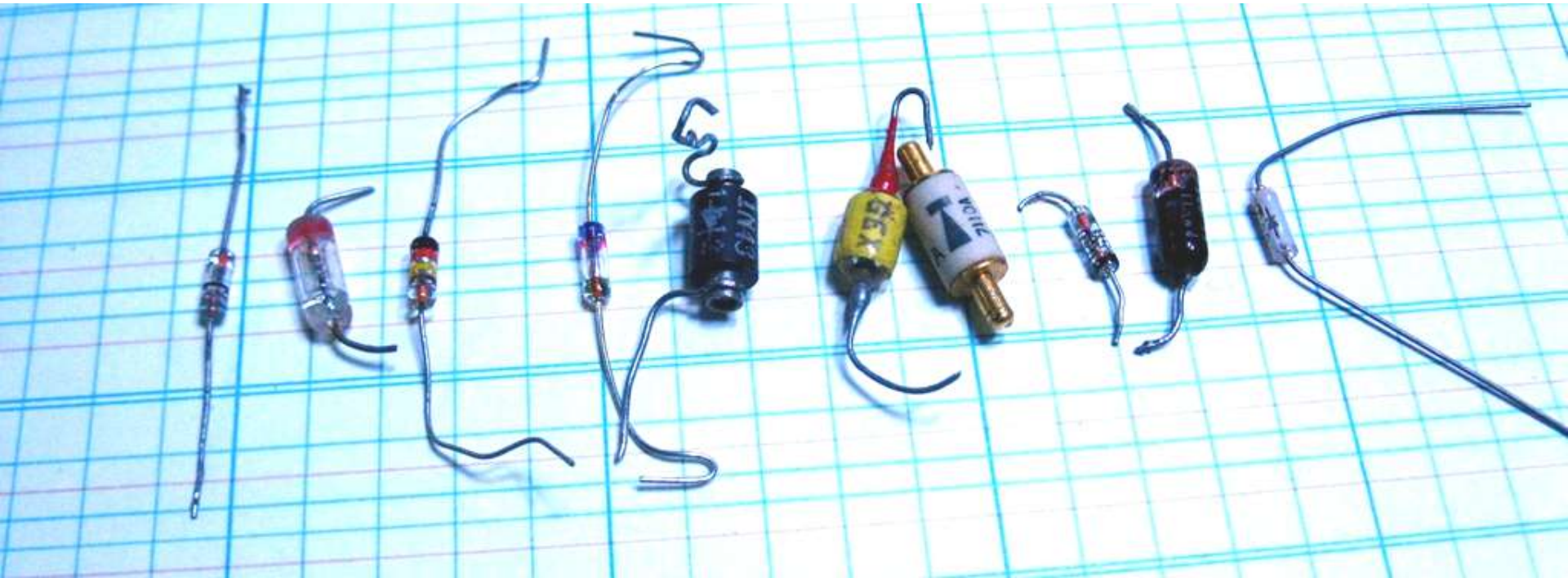

Detectors: I-V Curves

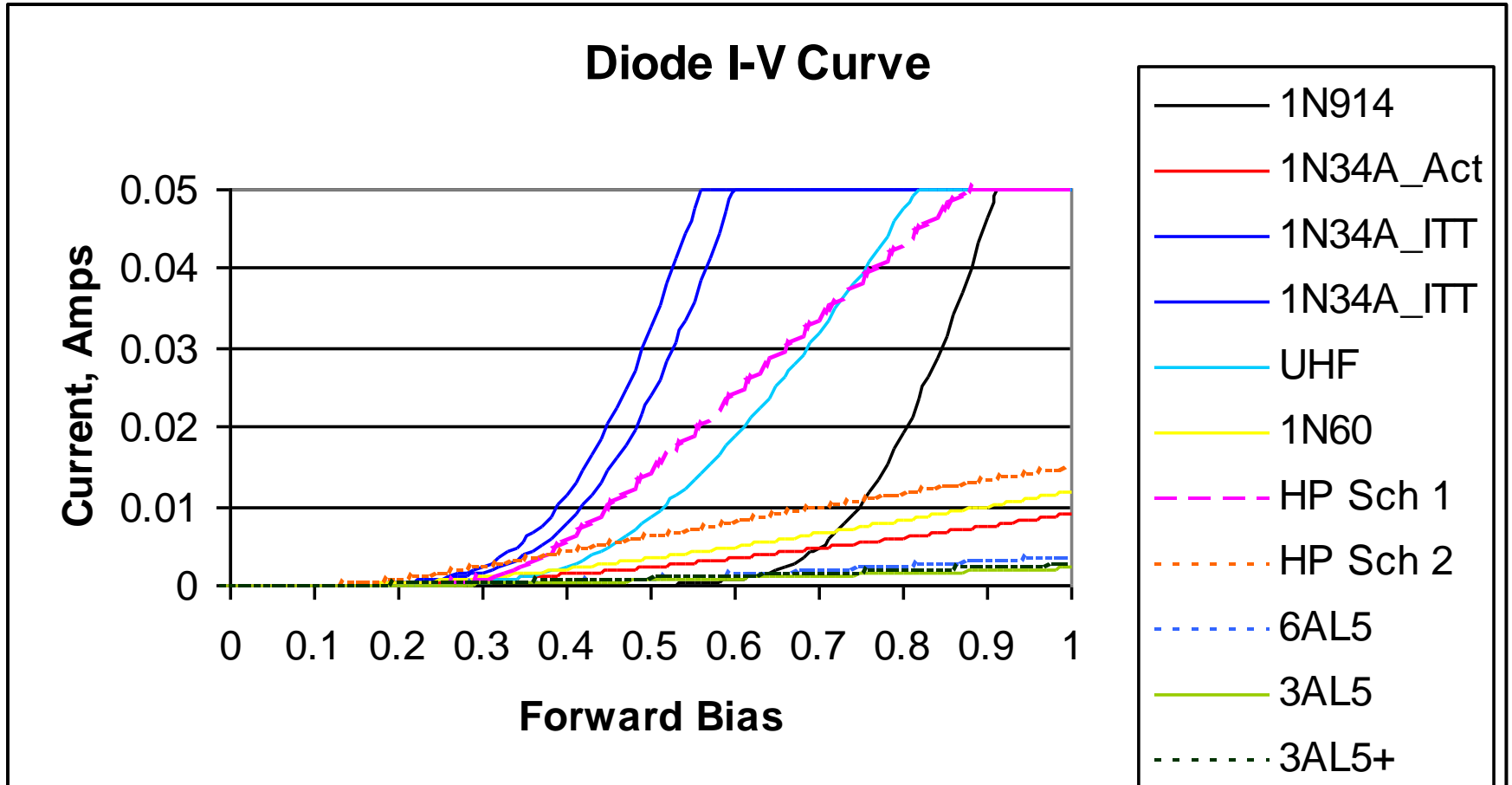

Detectors: I-V Curves

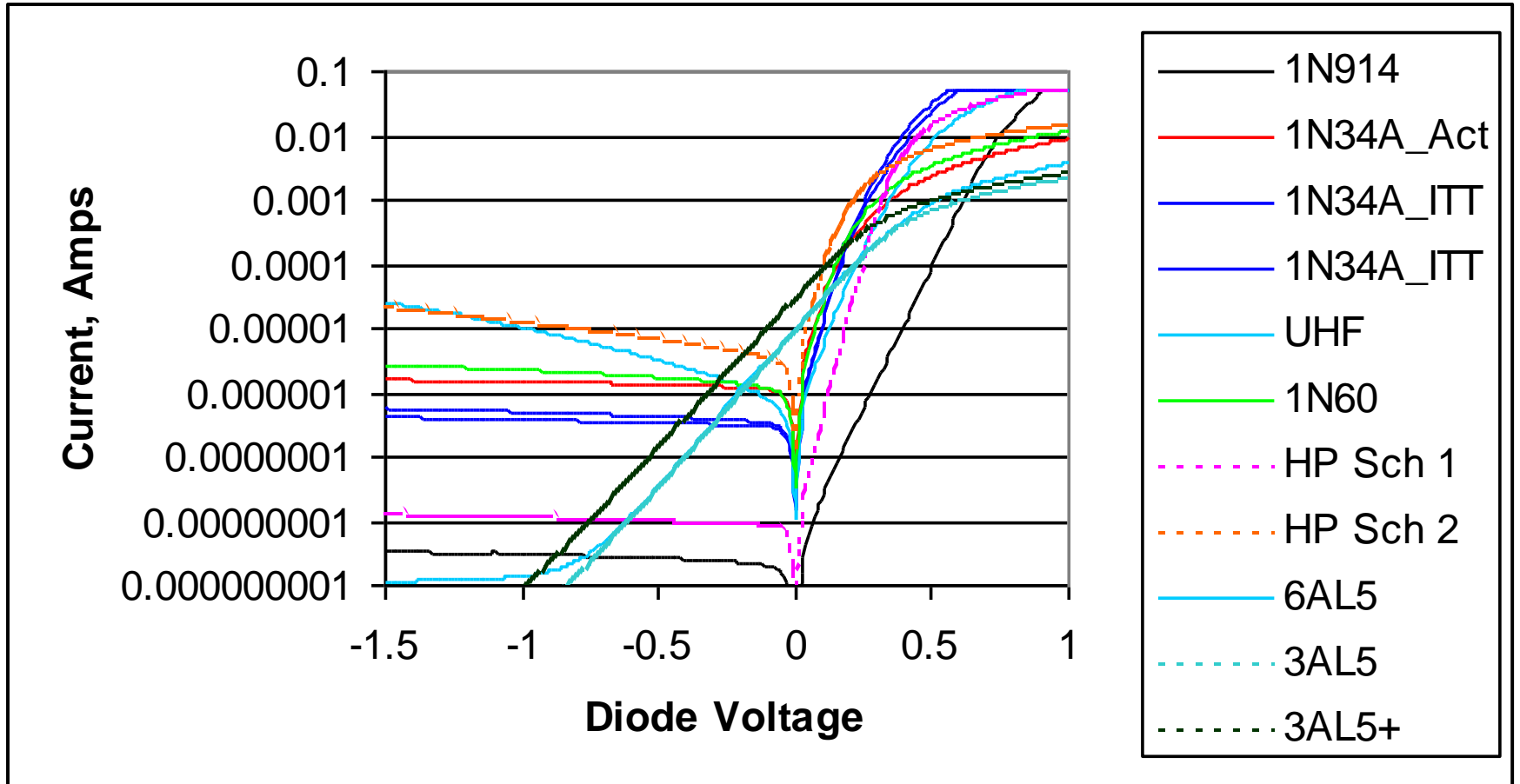

Mineral Detectors

Lead Sulfide, PbS (Galena), Iron Pyrite, Zincite, and other minerals have been used to make detectors (surprisingly good).



Mounted on copper
with silver epoxy

Embedded into
solder

Galena Chunks

Commercial
mounted Galena



Galena Detector



Galena mounted in solder



X-Y-Z manipulator

Audio Transducer



www.crystalradio.net

- Best transducers (headphones) for crystal radio operation are “Sound Powered” headphones or “Deck Talkers”.
- Developed in WWII for the navy to allow communications between the observers and gunners without the need for external power source.
- So sensitive that the pressure of the talkers voice in the microphone is sufficient to drive the headphones of the listener.

C1a

C1b



Audio Transducer

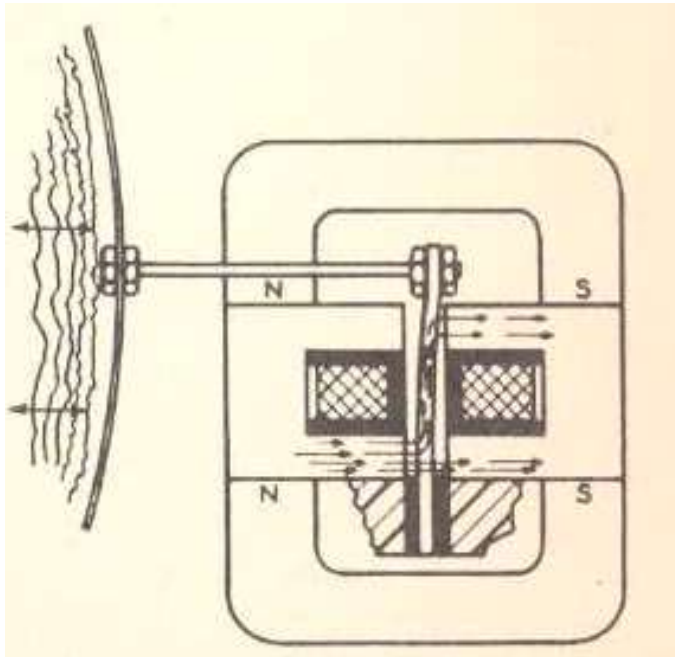

www.crystalradio.net

- An elaborate mechanism (balanced armature system) give the sound powered headphones their sensitivity.
- Impedance typically around 1000 ohms, much too low for direct use in a crystal set. An impedance matching transformer is essential.
- Microphone transformers are excellent choices for matching the impedance of the diode to the headphones.

Final Results

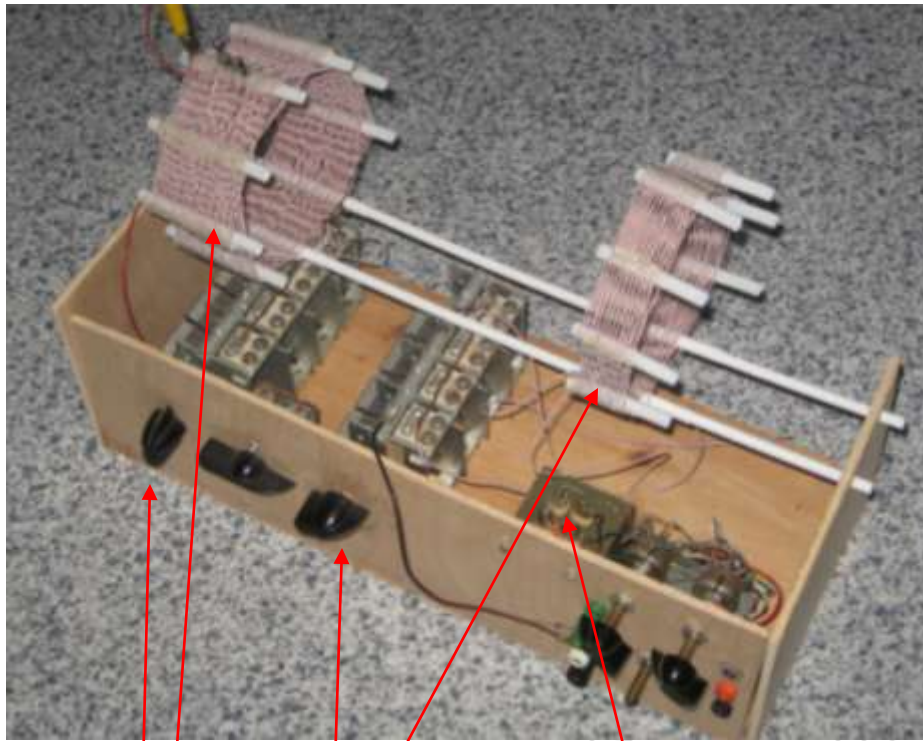

- Litz wire basket wound with taps for experimentation.
- Series antenna tuner above 650kHz. Below 650kHz, capacitor has to be placed in parallel with the inductor
- Ceramic insulated variable capacitors for maximum Q
- R-C allows DC to build up, reduces detector loading and reduces distortion on local stations.

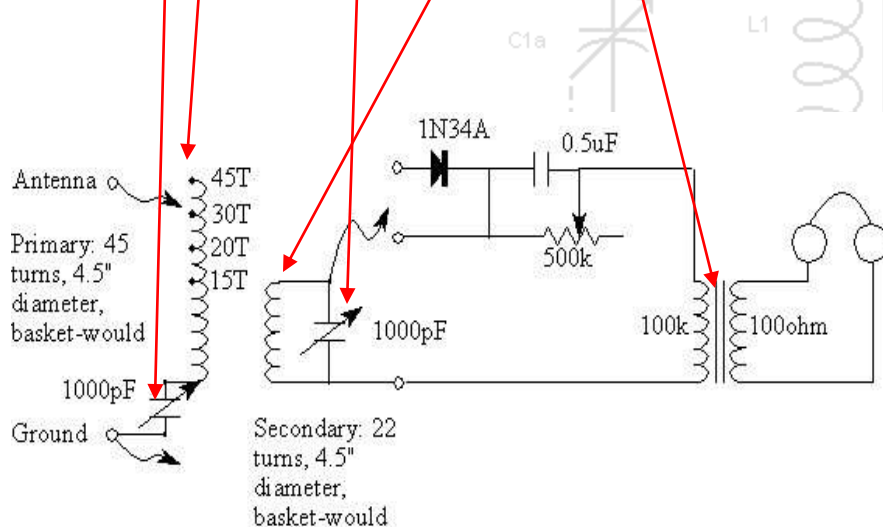

Clear Channel Stations

- Most of the distant stations we receive are 50,000 Watt “clear channel” stations.
- A clear channel station is a high power American station that shares its frequency with very few other stations
- The realization that a station nearly 1000 miles away can be heard in a completely passive crystal radio is amazing

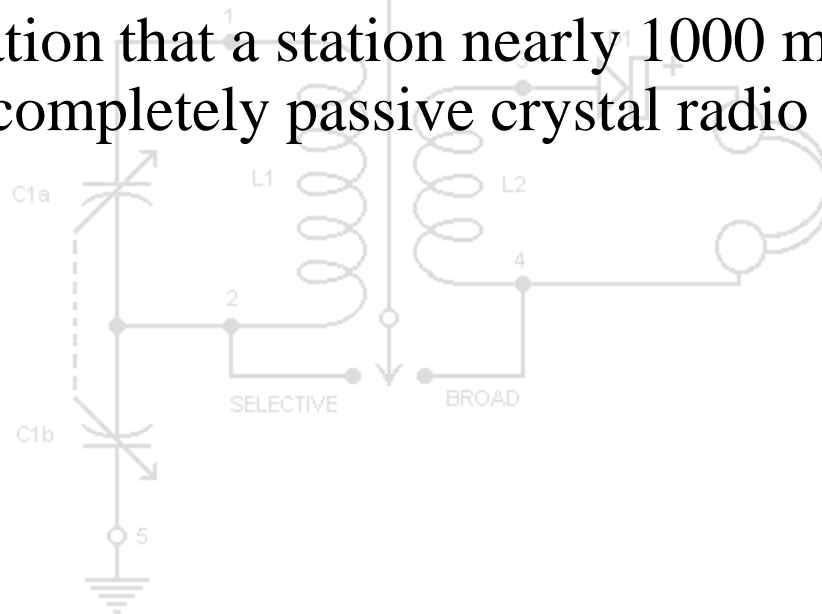

Clear Channel Stations

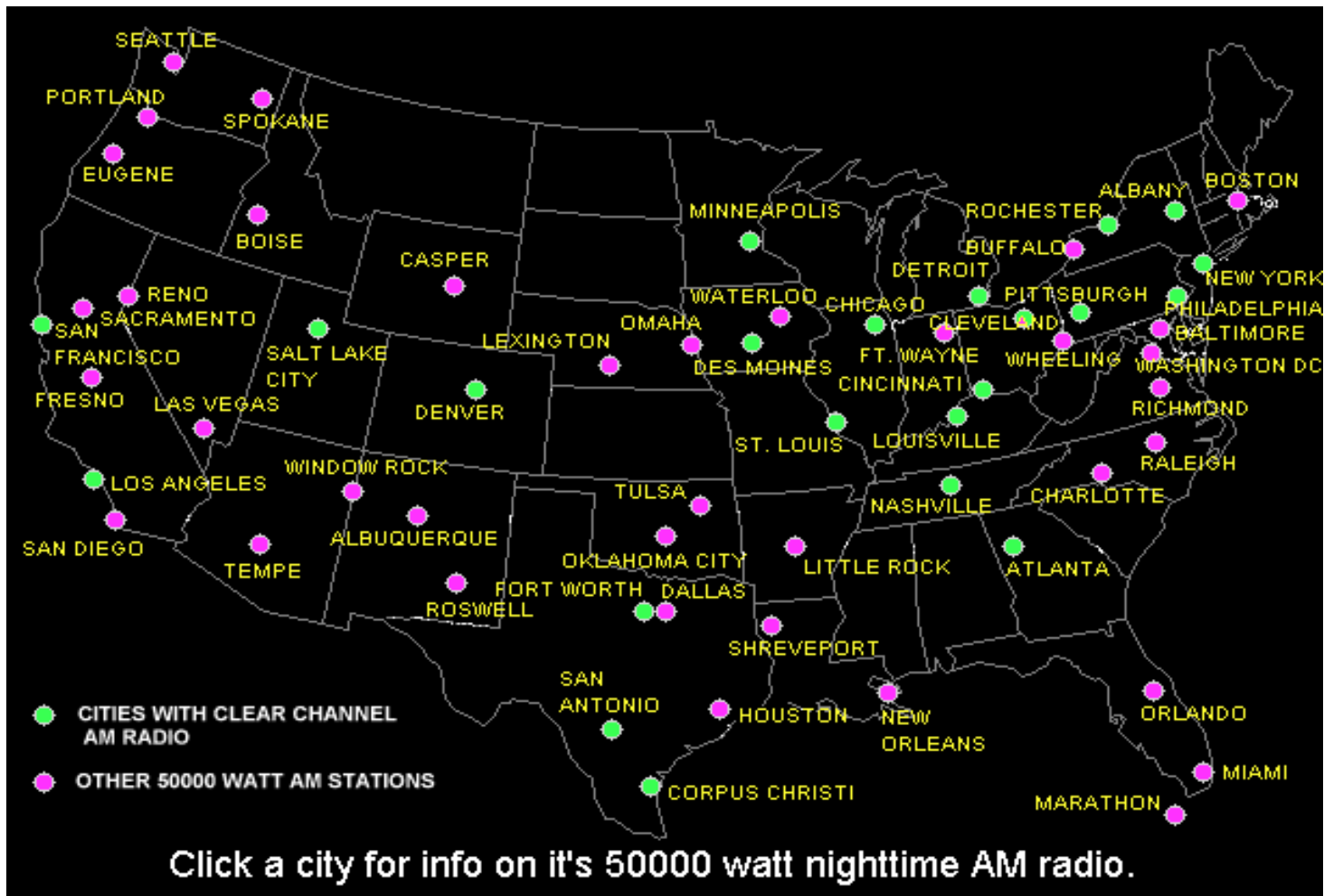

- <http://www.fortunecity.com/tinpan/bluenote/706/namrp/amradio.htm#anchor3>

Stations Logged

- 640 CFYI, Toronto
- 660 WFAN, New York City
- 680 CFTR, Toronto
- 690, Montreal
- 700 WLW, Cincinnati
- 720 WGN, Chicago
- 740, Toronto
- 760 WJR, Detroit
- 770 WABC, New York City
- 780 WBBM, Chicago
- 800 CJAD, Montreal
- 810 WGY, Schenectady
- 840 WHAS, Louisville
- 880 WCBS, New York City
- 920 WHJJ, Providence
- 940 CINW, Montreal
- 990 The Team, Montreal
- 1000 WMVP, Chicago
- 1010 CFRB, Toronto
- 1020 KDKA Pittsburgh
- 1030 WBZ, Boston
- 1060 KYW, Philadelphia
- 1080 WTIC, Hartford
- 1500 WTOP Washington
- 1520 WWKB, Buffalo
- 1560 WQEW, New York City

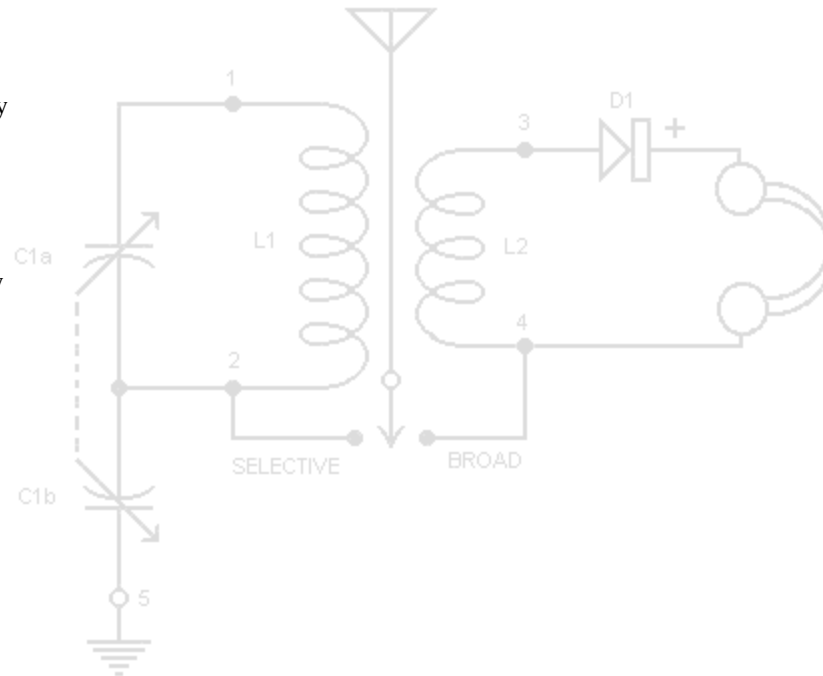

Top Performers

- Mike Tuggle of Hawaii is one of the top builders of crystal sets.
- His set, the Lyonodyne-17 has heard stations in Cuba from his home location in Hawaii!
- There are lots of web resources available. This presentation describes my efforts.



www.crystalradio.net



Conclusions

- Crystal sets appear to be simple, but attention must be paid to all the details.
- If you truly understand a crystal radio, you have a good foundation to RF engineering in general.



Lyondyne-D, back view

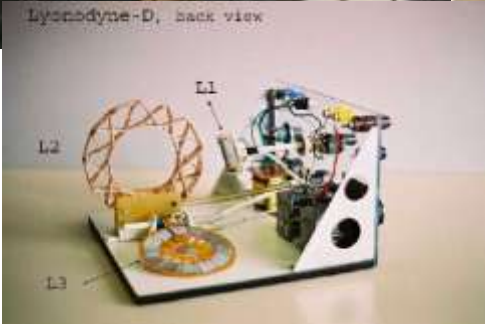

The "Litz Blitz"
January, 2004